

HEPARIN PUMP SUBSYSTEM

■ **Teoresi MedTech Heparin Pump** is a sub-system intended to be integrated in extra-corporeal blood circulation devices or in other medical devices that manage fluids. The pump can work both in continuous and bolus mode and includes sensor to detect output line occlusion. Safety features allow to implement redundant protective channels.

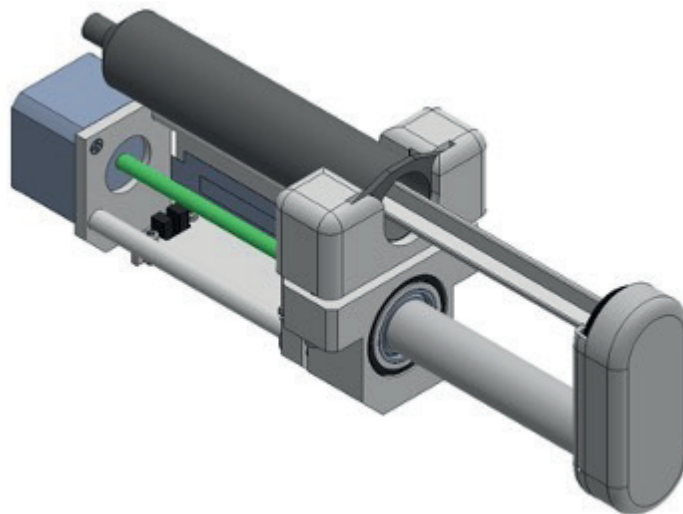

Key features include:

- Low noise linear stepper motor
- Encoder for protective safety channel
- Load cell on plunger to detect line occlusion
- Reflective object sensor for syringe presence detection
- RS-458 communication line to send commands and read pump status
- Designed to be tested in compliance with medical standards
- Continuous and bolus operation

TECHNICAL DATA

Power supply	24Vdc power supply for controller
Maximum motor current	2A peak current
Motor winding connections	Bipolar
I/O	Two channel quadrature output, 1024 counts per rev. (intended for external protective safety channel)
Data Interfaces	RS-485
Connectors	<ul style="list-style-type: none"> ▪ JST connectors type XH for signal IO ▪ JST connector type VH for power supply
Environmental operative range	<ul style="list-style-type: none"> ▪ Temperature -20 to +45 °C ▪ Humidity 5 to 95 % non condensing
Motor control features	<ul style="list-style-type: none"> ▪ Sinusoidal microstepping (1/16 step) ▪ Open loop position and speed control - no encoder required: encoder can be used as redundant channel on a protective system ▪ Low noise control algorithm - closed loop current control at driving sine wave frequency (high torque, ultra silent operation) ▪ Overcurrent hardware and software protection
Safety features	<ul style="list-style-type: none"> ▪ Reflective object sensor for syringe presence detection ▪ Load cell on plunger to detect line occlusion, operative range 100-600 mmHg ▪ Two channel quadrature output, 1024 counts per rev. (intended for external protective safety channel)
Host/Master communication	<ul style="list-style-type: none"> ▪ Proprietary protocol on RS485, commands: <ul style="list-style-type: none"> - start / stop commands - mode of operation : continuous / bolus - flow rate for continuous mode - bolus size and period for bolus mode ▪ data: <ul style="list-style-type: none"> - plunger position - processed volume - syringe presence - pressure on plunger
Syringe compatibility	<p>Tested on *:</p> <ul style="list-style-type: none"> ▪ BD Plastic 50 ml ▪ Pentaferte 50 ml ▪ Pic Indolor 50 ml <p>* may be tested on other syringes</p>
Standard references	<p>Designed for use in devices to be tested according to the following standards:</p> <ul style="list-style-type: none"> ▪ IEC 60601-1:2005+A1:2012+A2:2020 ▪ IEC 60601-1-2:2014+A1:2020 ▪ IEC 60601-2-16:2018 <p>Operating software designed according to</p> <ul style="list-style-type: none"> ▪ IEC 62304:2006+A1:2015 (Class C)